



Fixing Instructions

Altona Towel Rail



Please unpack your delivery carefully and inspect the radiator and contents – any damages or shortages must be notified to your supplier **within 3 days of delivery** of your goods.

Specifications

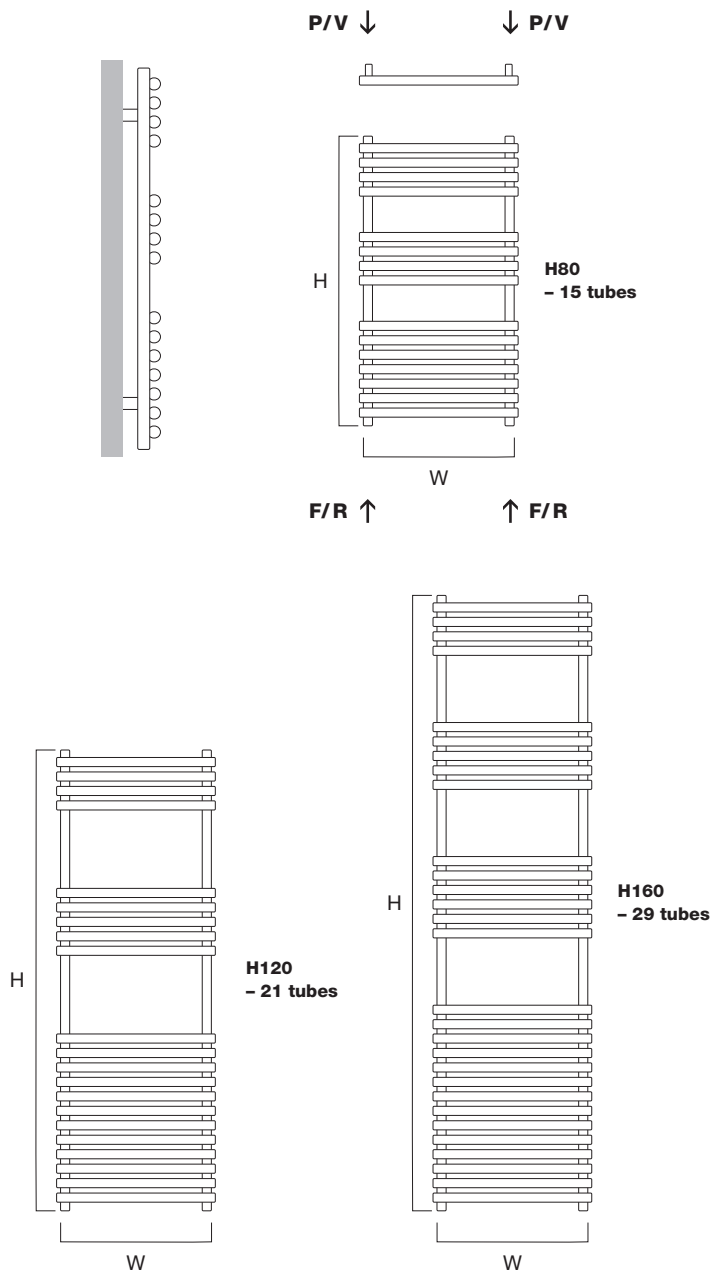

Technical Information

Standard connections: ½"

F = Flow **R** = Return

P = Plug **V** = Vent

Wall to front face = 90-100mm

Wall to pipe centre = 50-60mm

Technical Specifications

Materials: Mild Steel

Connections: ½" Flow and Return

Test pressure: 10 Bar

Testing authority: EN442

Max operation pressure: 7 Bar

Max working temperature: 90c

These can be cleaned using a soft damp cloth with a non-abrasive cleaning product.



PLEASE NOTE: That in accordance with Part L1 2006 of the Building Regulations and BS7593:1992 code of practice for the treatment of hot water and central heating systems, we recommend flushing the heating system before installation of new radiators and then adding the correct quantity and type of inhibitor for use with the radiator and system to prevent corrosion. Damage caused to systems not protected by a suitable inhibitor will not be covered by the manufacturer warranty. It is the responsibility of the installer to ensure the correct use and suitability of the fixings provided. No liability for costs or damages arising from failure to do so can be accepted.

Content list & Tools required



Review instructions carefully before installation.

Installation should be completed by a suitably qualified person.

Please dispose of packaging in a responsible manner.

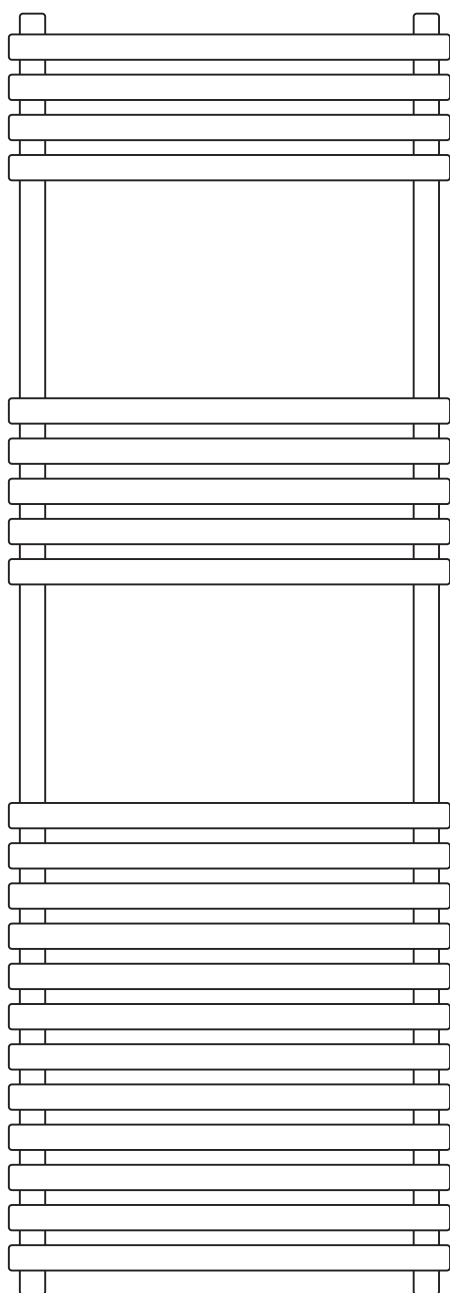

Contents list

Ref	Icon	Description	Qty
1		Blanking Plug	1
2		Air Vent Plug	1
3		Wall Support	4
4		Masonry Wall Plug	4
5		Long Screw	4
6		Small Screw	4
7		Spacer	4
8		End Cap	4
9		Cross Bolt	4
10		Bracket Bush	8
11		Rubber Ring	4

Tools required

	PTFE Tape
	Large Flat Screwdriver
	8.0mm Masonry Bit
	Socket Set
	Spanner
	Electric Drill
	Clean Cloth

Installation Instructions



Prior to Installation

Check that all of the parts are enclosed as per the contents list.

If there are any missing or damaged parts please contact your supplier immediately.

The four plastic caps on each corner of the ladder rail should be removed and disposed of.

Ensure that the ladder rail is positioned so that it can be easily connected to the central heating system.

Select your desired installation position and ensure that the wall is sufficiently strong enough to hold the weight of the ladder rail. Brick or breezeblock walls are ideal. If positioning on plasterboard wall it **MUST** be fixed to timber batons.

A

Screw the blanking plug **1** and air vent plug **2** into the top two threads in the upright channels of the ladder rail. They can be fitted on either side. Using a cloth to prevent scratching, tighten them with a spanner. Apply **PTFE** tape.

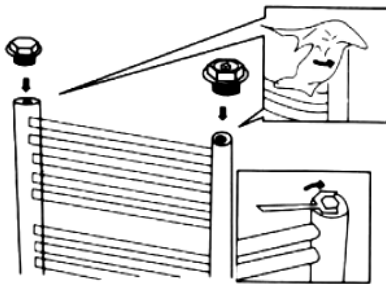

B

Thread the tails from the radiator valves (not supplied) into the bottom two threads. Apply **PTFE** tape.

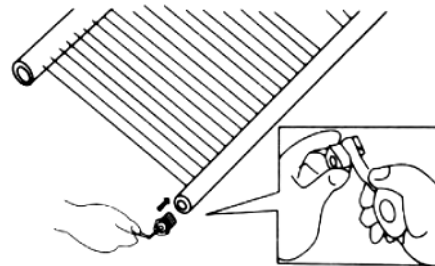

C

The wall supports should be fitted at approximately 10cms from the inside edge of the ladder rail-2 near the top of the ladder rail and 2 near the bottom. The mounting height can be varied between any of the ladder rail bars to allow for finding the best fixing point on the wall. Mark the fixing points with a pencil.

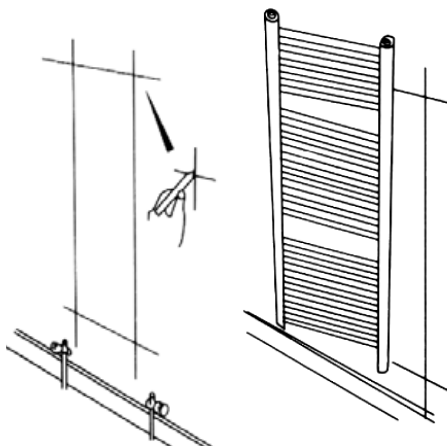

D

Mounting to Brick or Breezeblock - At the required fixing positions drill hole using 8mm masonry bit and insert the wall plug **4** into the hole ensuring it's flush with the wall. Place long screw **5** through the centre of the wall support **3** and tighten into the wall plug. Mounting to Wood - Place long screw **5** through the centre of the wall support **3** and screw into the wooden baton at the required fixing positions.

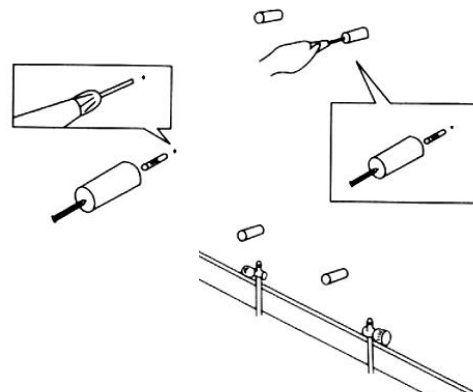

E

Place the spacer **7** inside the wall support and insert the small screw **6** into the hole in the wall support. Don't over-tighten to allow for adjustment later.

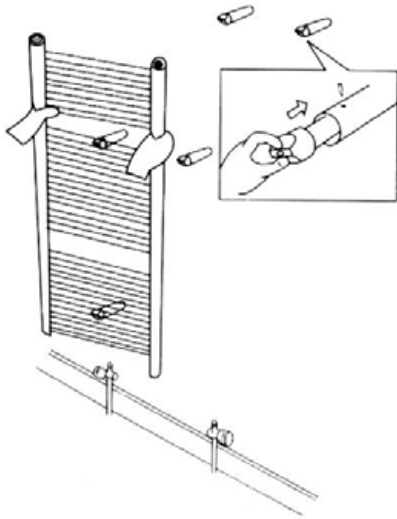
**F**

Offer the ladder rail up to the fixing brackets and place bolt **9** through the bracket bush **10**.

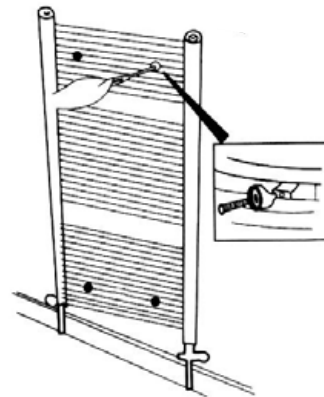

Place the bolt between the selected ladder rail bars and thread into the wall support ensuring the square face of the bracket bush is aligned with the ladder rail.

G

Push the rail flat against the wall, adjust to required depth and tighten the small screws to secure. Push the end caps | over each of the bracket heads until they click into position.

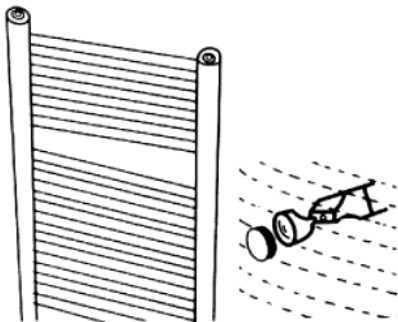
**H**

Connect the radiator valve tail to the radiator valve and tighten securely. Apply **PTFE** tape.

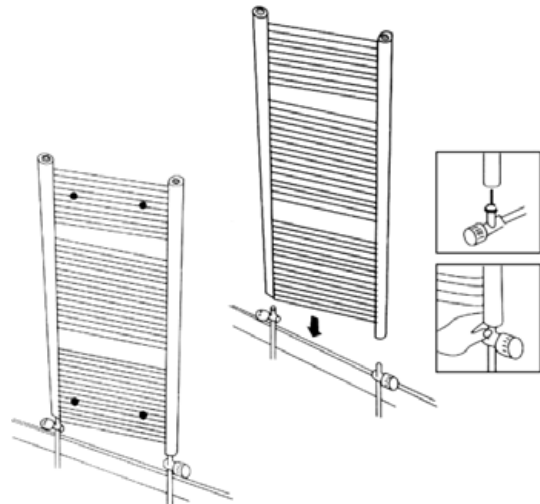

Important

Ensure that your central heating system is thoroughly flushed before use to rinse out any foreign residues.

Wipe the surface clean with a soft, damp cloth. Never use abrasive cleaners on this product as they will damage the surface.

It is recommended that a suitable inhibitor be added to the central heating system to help prevent internal corrosion and limescale build-up.

Terms and Conditions

You must immediately remove all packaging, inspect the goods and notify us of any damage to the goods within 3 days of delivery. We shall have no obligation to replace or repair damaged goods in the event of failure by the Buyer to comply with this provision. Radiators which are off an unacceptable standard or are damaged must not be installed. If any items is installed it will be treated as being as accepted as received.

Damaged goods being returned will only be collected from your delivery address, unless otherwise agreed in writing. Any other goods, which we accept back, are to be returned by you to our place of business at your expense.

Items will be accepted as a return which have not been installed or damaged after delivery. We do not accept liability for any damages sustained after delivery. Goods should be returned in their original packaging, provided such packaging and goods are undamaged.

We may issue a credit note for goods which we accept as returned.

We may agree to provide you with replacement goods prior to collecting or receiving back the goods to be returned (whether faulty, damaged or otherwise) but only on the condition that: the replacement goods are paid for in full and we reserve the right to re-invoice you in the event that the returned goods are found to be in a worse condition than when they were originally received by you or where such goods have not been received back to us within 3 months of the replacement goods being received by yourselves. A re-stocking charge of 30% will be applied to all non-faulty stock items that wish to be returned. Special order and non-stock products cannot be cancelled. Where cancellation or alteration of orders is accepted by us, you may be required to pay a restocking charge, to cover administrative costs and collection costs (if applicable); such charges to be determined by us. If the goods we deliver are faulty or damaged, we will meet the cost of the return, as long as the fault is reported to us within 3 working days.

The goods will be deemed to have been accepted when they have been delivered and we may not accept claims for any visible defects found after installation.

We accept no liability for any cost incurred relating to the cost of installation.

We shall not be liable for any plumber's costs, decorator's costs, transport costs, late penalties, or any other costs, as a direct or indirect result of (i) any defect in the goods (including but not limited to any manufacturing faults, such as leaks, that become apparent on or after installation) or (ii) late delivery of the goods.

GUARANTEES AND LIABILITIES – we are not the manufacturer of this product we will take all reasonable endeavours to make over to you the benefit of any warranty or guarantee given by the manufacturers. The item must have been fitted in accordance with British and or European standards as well as these fitting instructions.

